

STANDARD RANGE MORSE TAPER SHANK MULTIPLEX HOLDERS

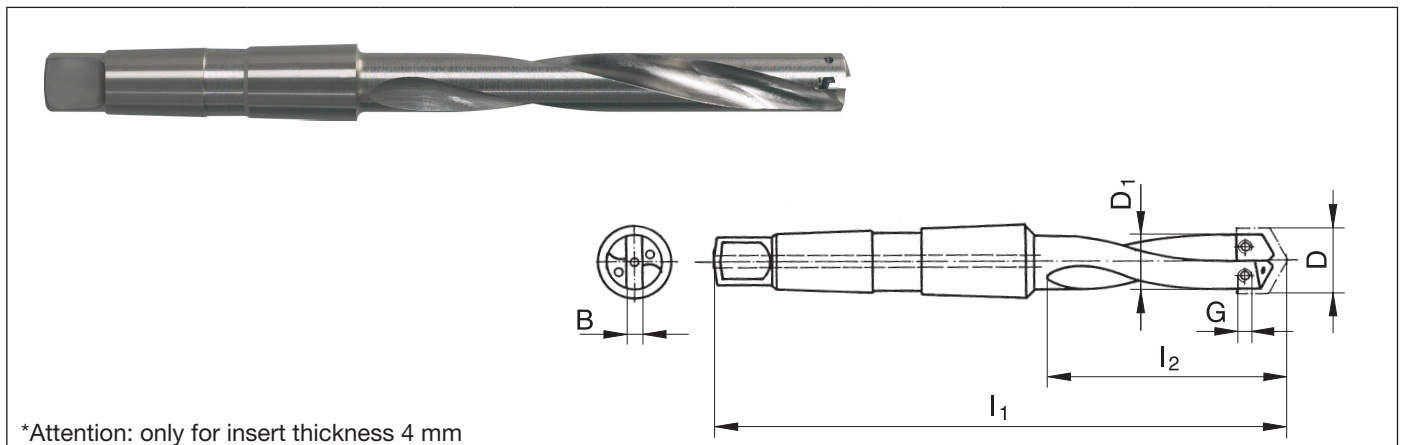

*Attention: only for insert thickness 4 mm

86650 long, axial coolant delivery, radial coolant delivery on request

Hole Ø-range D mm	Total length l ₁ mm	Flute length l ₂ mm	Morse taper	Holder-Ø d ₁ mm	Width of slot B mm	Torx screws 86807		Screw driver size	Code no.
						Size	Code no.		
9.70 - 11.70	186	103	2	9.5	2.5	M 2x4	2.000	T 6	09.500
11.71 - 13.40	191	108	2	11.5	2.5	M 2x4	2.000	T 6	11.500
13.41 - 16.40	210	125	2	13.0	3.5	M 2.5x5	2.500	T 7	13.000
16.41 - 18.90	218	135	2	16.0	3.5	M 2.5x7	2.501	T 7	16.000
18.91 - 22.40	258	156	3	18.5	4.0	M 3x6	3.000	T 9	18.500
22.41 - 25.40*	266	165	3	22.0	4.0	M 3x8	3.001	T 9	22.000

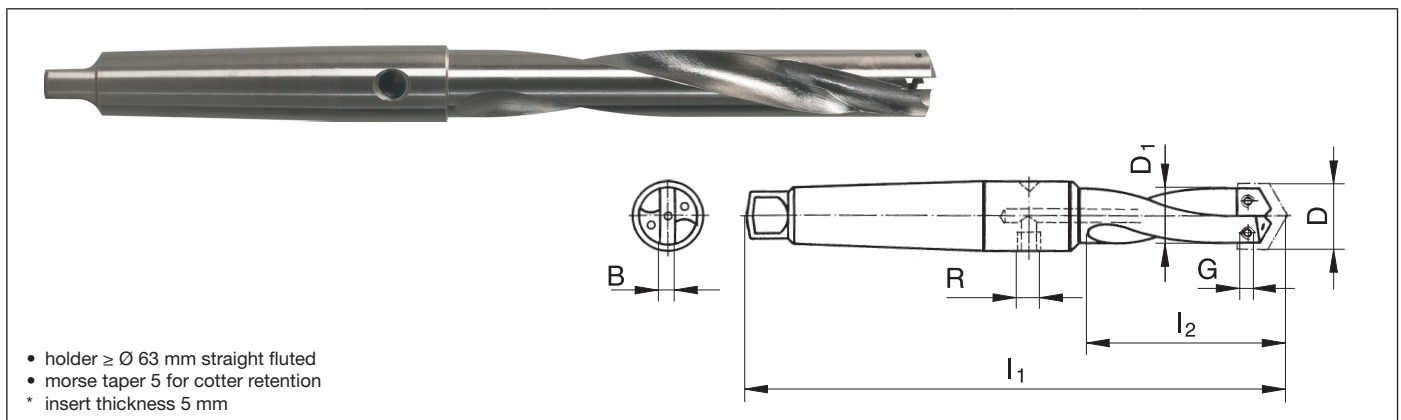

- holder ≥ Ø 63 mm straight fluted
- morse taper 5 for cotter retention
- * insert thickness 5 mm

86680 long, radial coolant delivery, axial coolant delivery on request

Hole Ø-range D mm	Total length l ₁ mm	Flute length l ₂ mm	Morse taper	Holder-Ø d ₁ mm	Width of slot B mm	R	Torx screws 86807		Screw driver size	Code no.
							Size	Code no.		
25.01 - 29.00*	379	208	4	24	5	G 1/4"	M 3.5x10	3.500	T 15	24.000
29.01 - 35.00	379	208	4	28	5	G 1/4"	M 3.5x10	3.500	T 15	28.000
35.01 - 45.00	429	257	4	34	7	G 1/4"	M 4x15	4.001	T 20	34.000
45.01 - 55.00	429	257	4	44	7	G 1/4"	M 4x15	4.001	T 20	44.000
55.01 - 65.00	429	257	4	54	7	G 1/4"	M 4x15	4.001	T 20	54.000
65.01 - 78.00	536	316	5	63	9	G 1/2"	M 5x20	5.000	T 20	63.000
78.01 - 90.00	536	316	5	77	9	G 1/2"	M 5x20	5.000	T 20	77.000
90.01 - 102.00	536	316	5	89	9	G 1/2"	M 5x20	5.000	T 20	89.000