

ESCARIADORES MAQUINA HELICE 45j "CORTE DESCENDENTE"

45° QUICK-SPIRAL REAMERS

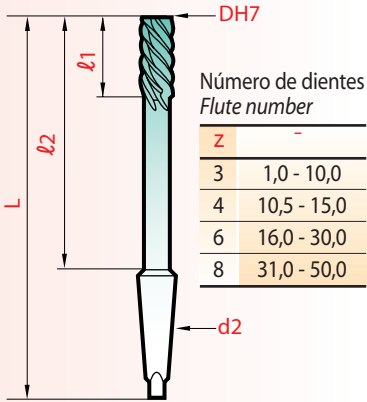

D	d2	l1	L
m5	h8	+ 1	± 1

Tolerancias generales / General tolerances

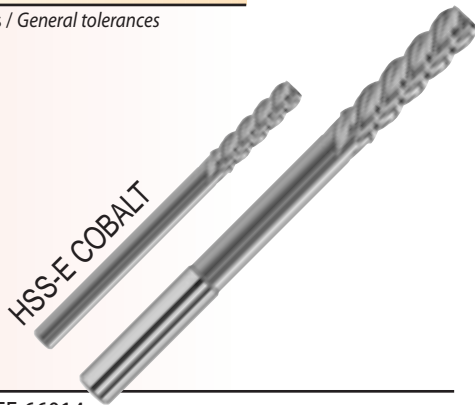

≈ DIN 212-E • NFE 66014

DH7 mm	L	l1	l2	d2	magafor 630
1,0	38	12	15	D	€ •
1,5	43	18	26	D	•
2,0	49	19	31	D	•
2,5-3,0	57	20	38	D	•
3,5	57	20	38	D	•
4,0	75	24	51	4,0	•
4,5	80	25	55	4,5	•
5,0	86	26	60	5,0	•
5,5	93	27	66	5,5	•
6,0 - 6,5	101	28	73	6,0	•
7,0 - 7,5	109	31	80	7,0	•
8,0 - 8,5	117	33	86	8,0	•
9,0 - 9,5	125	36	91	9,0	•
10,0	133	38	99	10,0	•
10,5 - 11,0	133	38	99	10,0	•
11,5 - 12,0	151	44	106	12,0	•
12,5 - 13,0	151	44	106	12,0	•
13,5 - 14,0	160	47	110	14,0	•
14,5 - 15,0	162	50	112	14,0	•

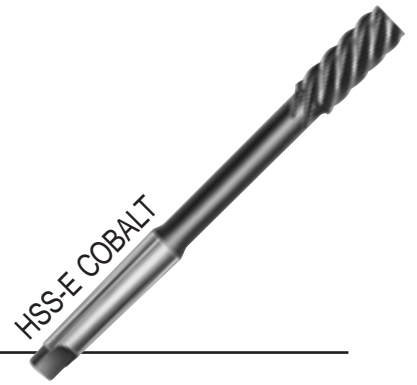

DIN 208-E • NFE 66015

DH7 mm	L	l1	l2	MORSE N _i	magafor 640
6,0	138	28	72	1	€ •
7,0	150	31	84	1	•
8,0	156	33	90	1	•
9,0	162	36	96	1	•
10,0	168	38	102	1	•
11,0	175	41	109	1	•
12,0	182	44	116	1	•
13,0	182	44	116	1	•
14,0	189	47	123	1	•
15,0	204	50	124	2	•
16,0	210	52	130	2	•
17,0	214	54	134	2	•
18,0	219	56	139	2	•
19,0	223	58	143	2	•
20,0	228	60	148	2	•
21,0	232	62	152	2	•
22,0	237	64	157	2	•
23,0	241	66	161	2	•
24-25	271	68	171	3	•
26	273	70	173	3	•
27-28	277	71	177	3	•
29-30	281	73	181	3	•
31-32-33	317	77	193	4	•
34-35	321	78	197	4	•
36	325	79	199	4	•
38-40	329	81	205	4	•
45	336	83	212	4	•
50*	344	86	220	4	•

* Entrega hasta finalizar existencias
Delivery up to stock consumption

